



# TUBE FILLER

TK800-M Aluminum Tubes

  
**Kentex**



# Kentex

## Kentex Group

KENTEX PACKING MACHINERY CO., LTD.

Kentex has been established in the spring of 1984, as a professional manufacturer of tube filling and sealing machines. With more than 30 years of experiences, and sustainable improvement, we have developed many custom-made models. "Customer Satisfaction" is our priority principle. We are continue providing good quality machines with stable production, and easy maintenance to meet clients' request.

Application: for low viscosity, medium, and high viscosity.

Covers:

- » **Pharmaceutical: ointments...**
- » **Cosmetics: cream...**
- » **Chemical: silicone...**
- » **Food: condensed milk, chocolate...**
- » **Others: hair color cream, toothpaste...**



Machine specifications:

- » **Mechanism transmission**
- » **Strengthen structure**
- » **Steady production**
- » **Accurate filling volume**
- » **cGMP standard**
- » **Easy changeover and maintenance**



## Tube holder ascending type filling

Tube holder pushed up to meet filling nozzle, makes the filling nozzle reach the bottom of tube. Filling and tube holder goes down slowly at the same time for minimizing air in.

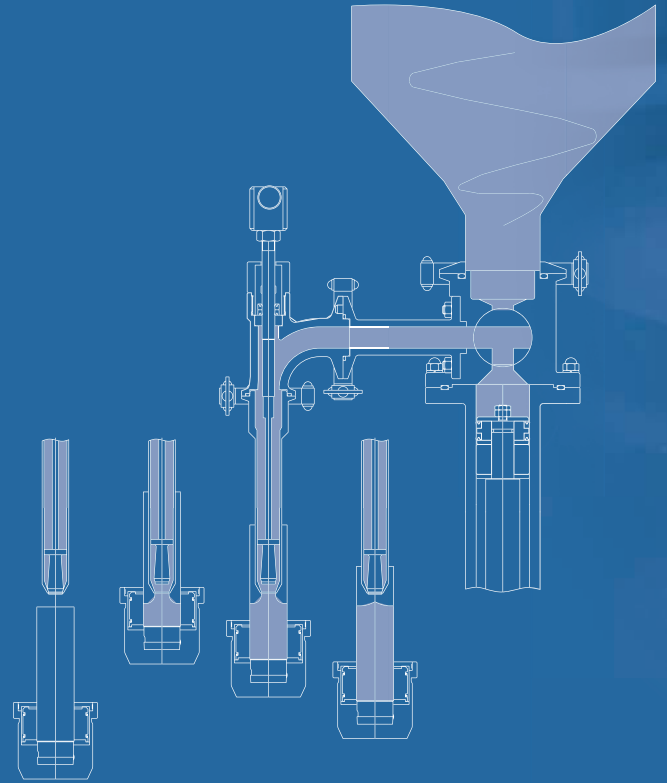

## Type of Tube Folding

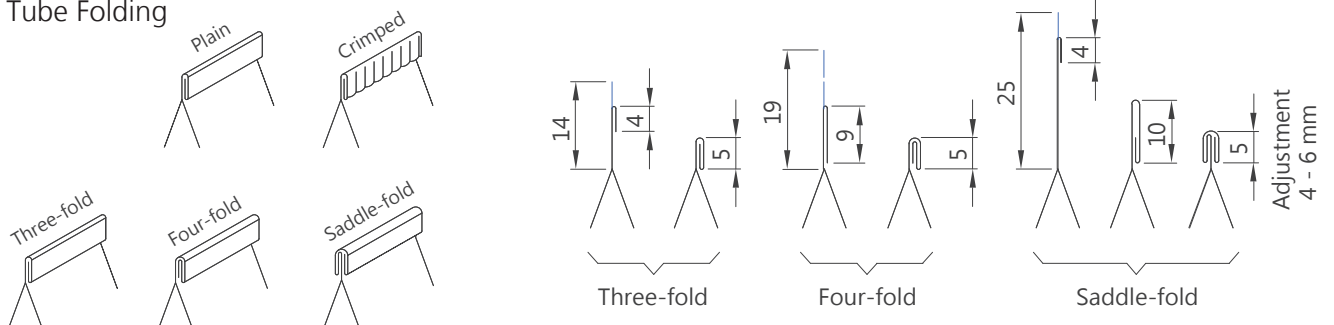





TK800-M

- » Fully automatic
- » One operator
- » Ascending filling



K600-M

- » Manual tube feeding
- » Automatic orientation
- » Descending filling



TK800-MN

- » Specialized for Hair color cream
- » Air-tight hopper
- » N<sub>2</sub>
- » Minimize air in

## TK800-M

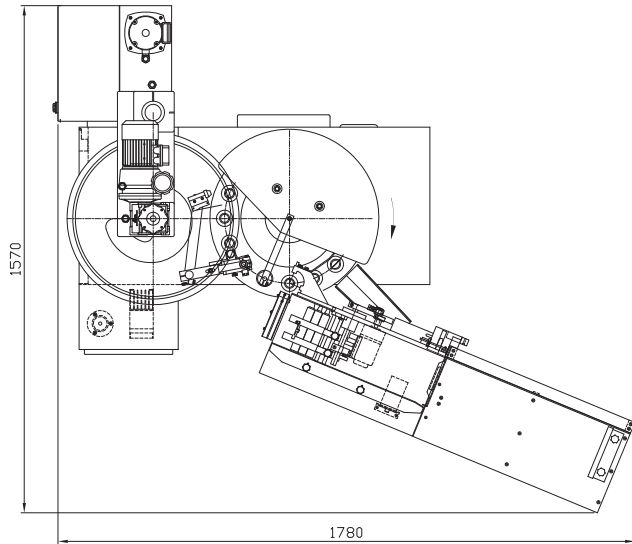

## K600-M

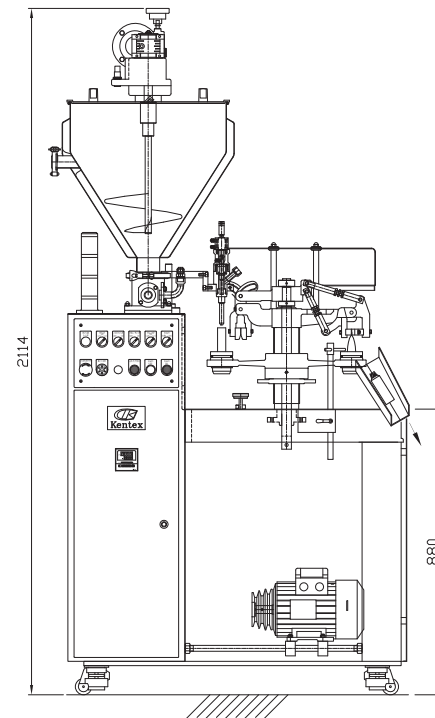
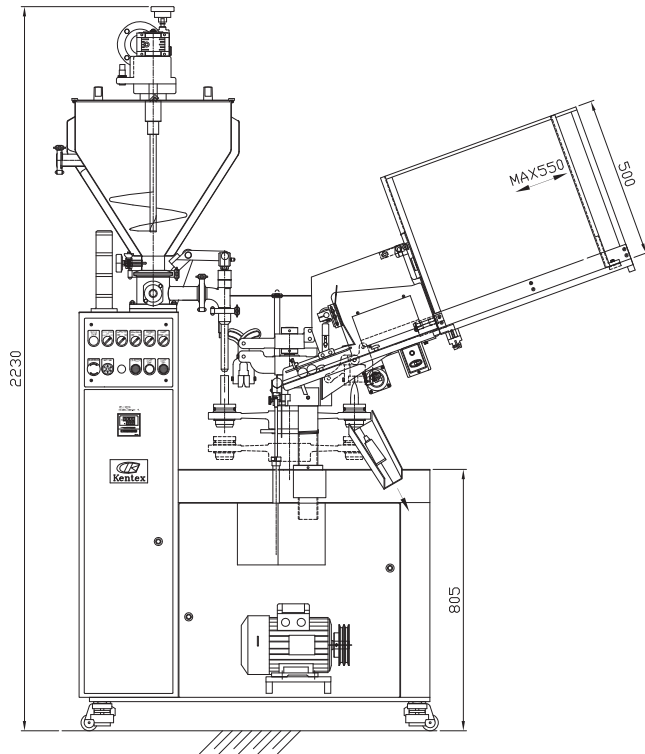
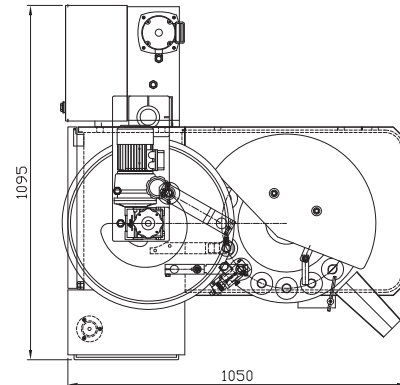

We reserve the right to change the above specifications.



**Kentex Group**

KENTEX PACKING MACHINERY CO., LTD.

Address: 6F, No.100, Hsin Teh Road,  
San Chung Dist., 24158 New Taipei City, Taiwan  
Tel: +886-2-2999 1688 / 2995 2080  
Fax: +886-2-2995 5425 / 2999 8796  
E-mail: kentexco@kentex-mc.com  
Web: www.kentex-mc.com